

Tuxgraphics Smartphone Garage Door Opener

(1 to 4 doors can be operated by a single board)

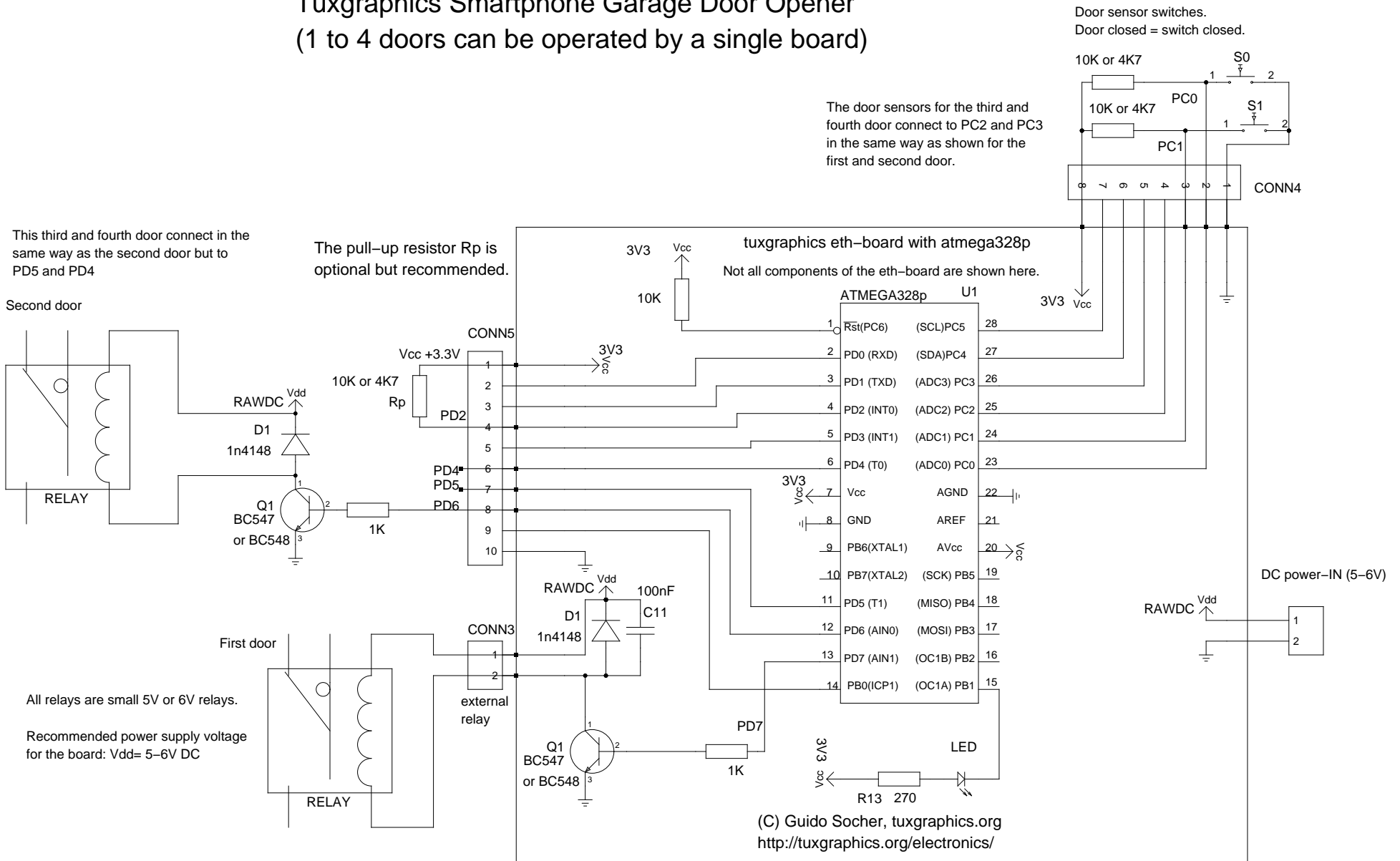

Note: different tuxgraphics ethernet boards have different connector layouts.
Important are only the pin names at the microcontroller such as PC0, PD6,...GND, Vcc3.3V...